

## Assembly guide

SNAP female S inset anchor  
+ tool 34

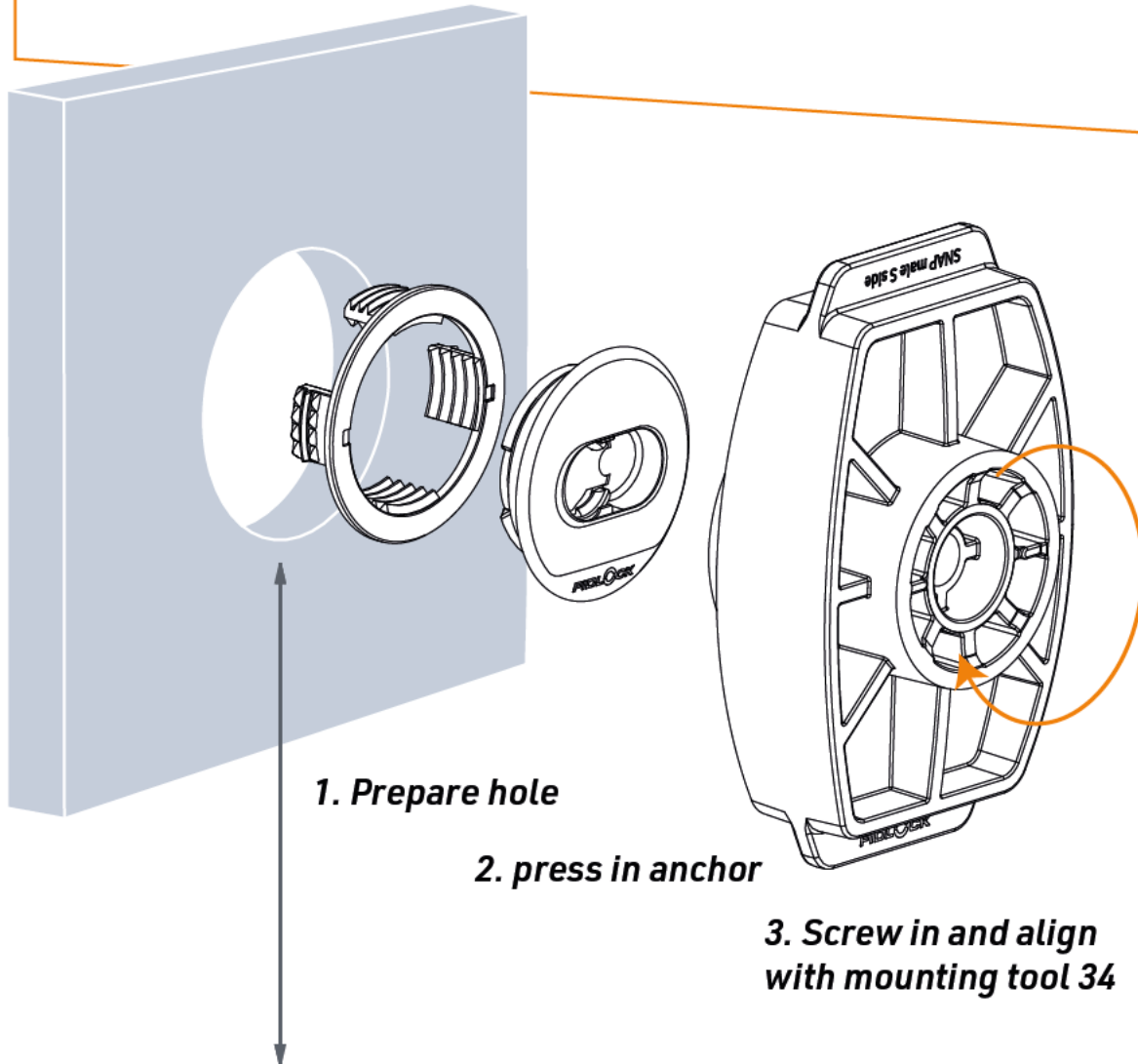

Section with assembled anchor

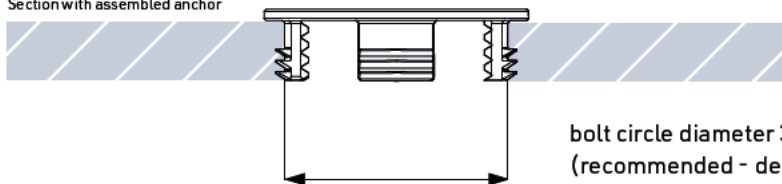

bolt circle diameter 30mm  
(recommended - depends on the material in which it is assembled)

### Logo positioning

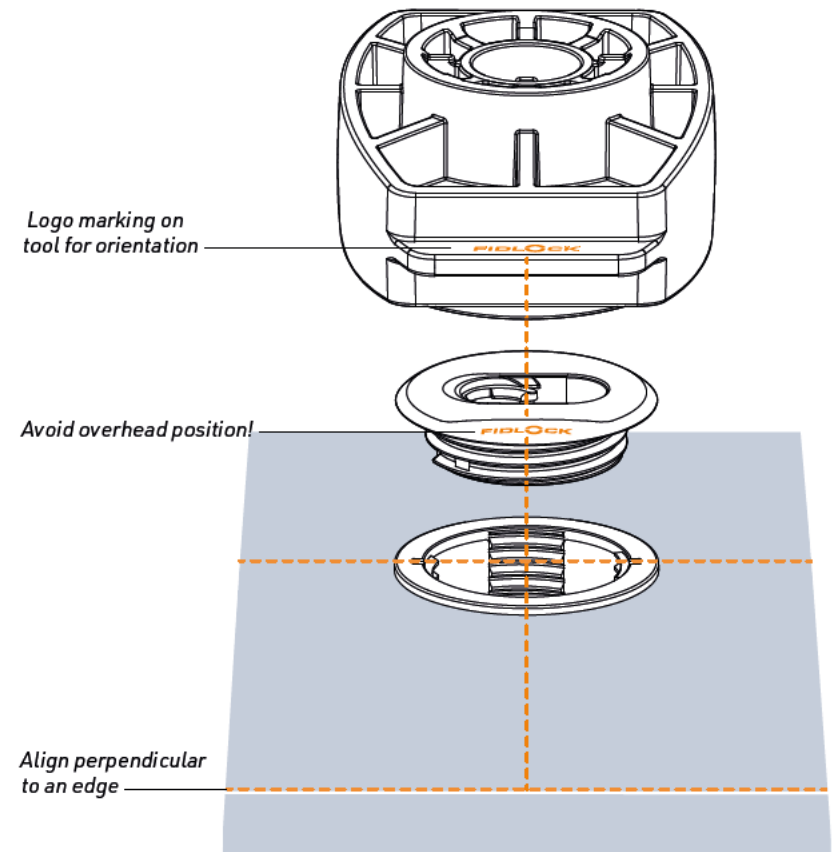

ARTICLE NO.	05517-000001 (BLK)
DATE	18.07.2024
AUTHOR	CK