

DATASHEET

STRIPE FW rope RC

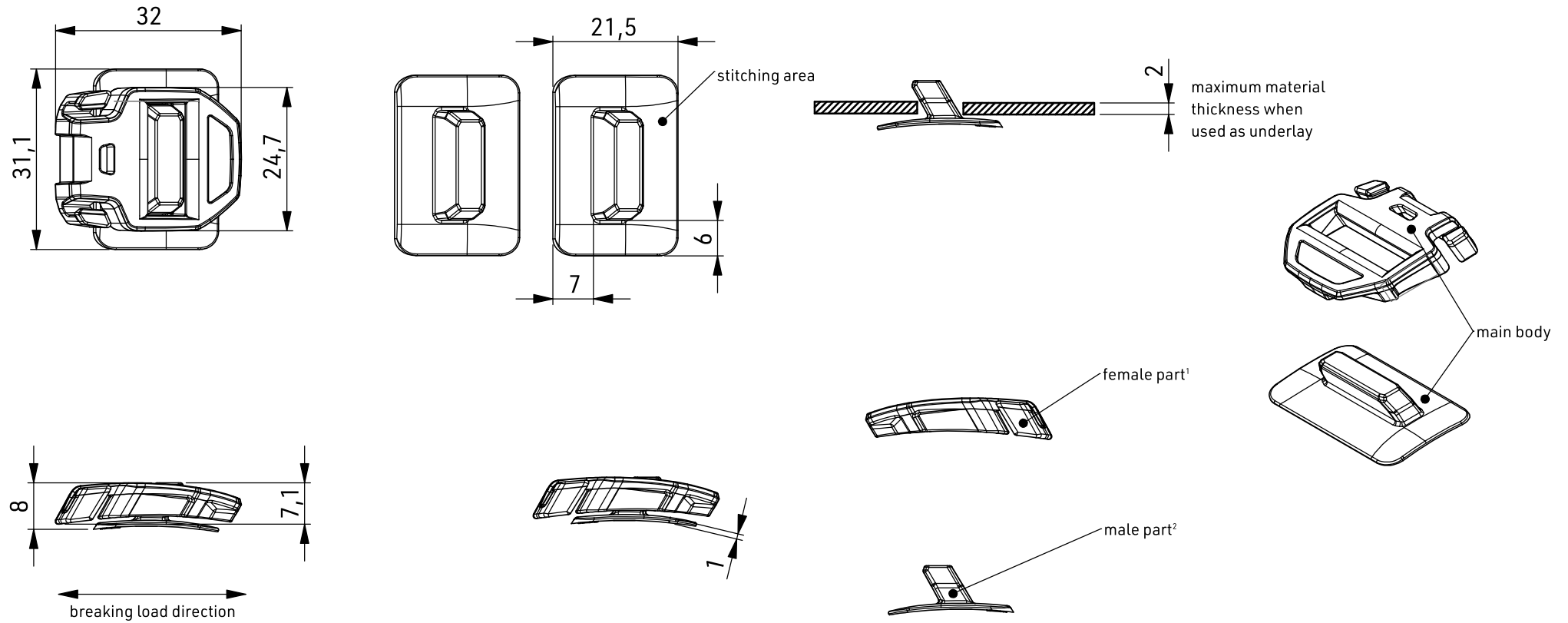

nominal values in millimeters [mm]

OPENING	lift
MATERIAL	PA6 ^{1,2} , NdFeB ^{1,2} , epoxy ^{1,2}
COLOUR	black (BLK), blue (5415) main body
WEIGHT	~7 g (weighed)
BREAKING LOAD**	n.a.

GENERAL NOTES*

Recycled material:
Not suitable for safety-relevant applications

Coloured options:
Colour may vary, due to raw material.
Minor dark particals may appear, due to raw material.

For rope assembly please see assembly guide.

Rope diameter: 1.8-2.5 mm
Recommended rope: synthetic fibre

ARTICLE NO.

F1390- 000002(BLK)R
F1390- 000002(5415)R

PRODUCT

STRIPE FW rope RC

SCALE

1:1 DIN A4

REVISION / DATE

R00 22.01.24

* The manufacturer of the end products in which FIDLOCK fasteners are used, bears the responsibility for thoroughly testing that the FIDLOCK products are suitable for the intended applications.

** According to test specification QM-TP-001