

FIDLOCK®

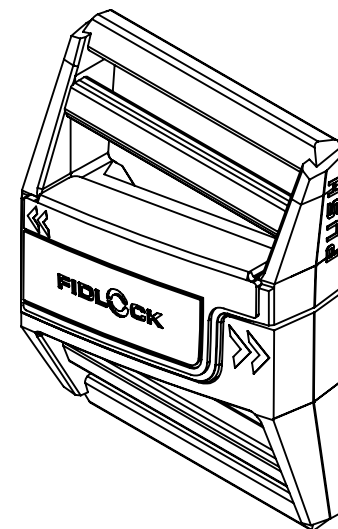
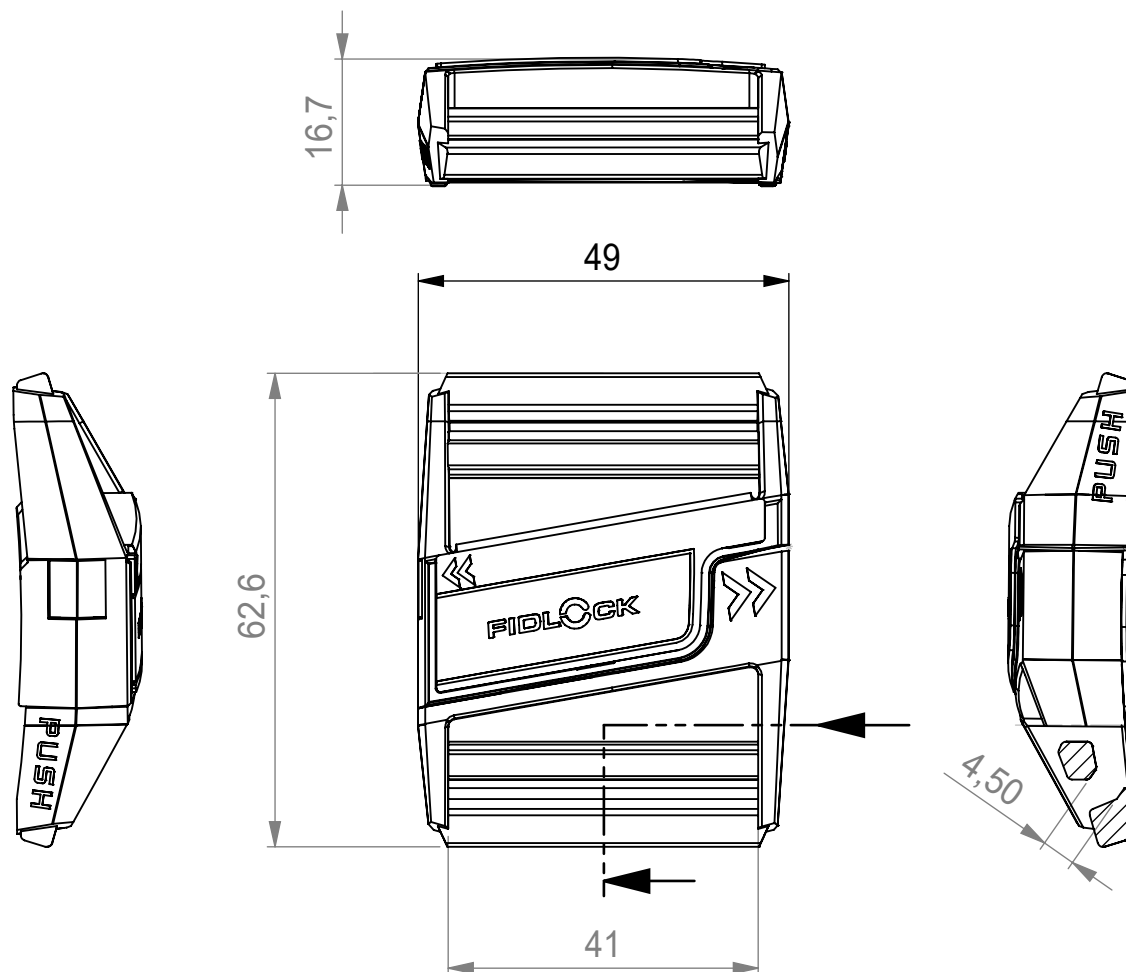

PRODUCT	Slider 40 Double LL
APPLICATION	
OPENING	slide sideways
MATERIAL	PA66 GF15, NdFeB, Epoxy
COLOUR	Black
COLORABLE	
WEIGHT	29 ~ g
LOAD CAPACITY	25 kg
GENERAL NOTES	

ARTICLE NO.	F4110-000002(BLK)
SCALE	1:1
DATE	15.02.2023
AUTHOR	MS

patented technology.