

SNAP push female S 15 LL

patented technology

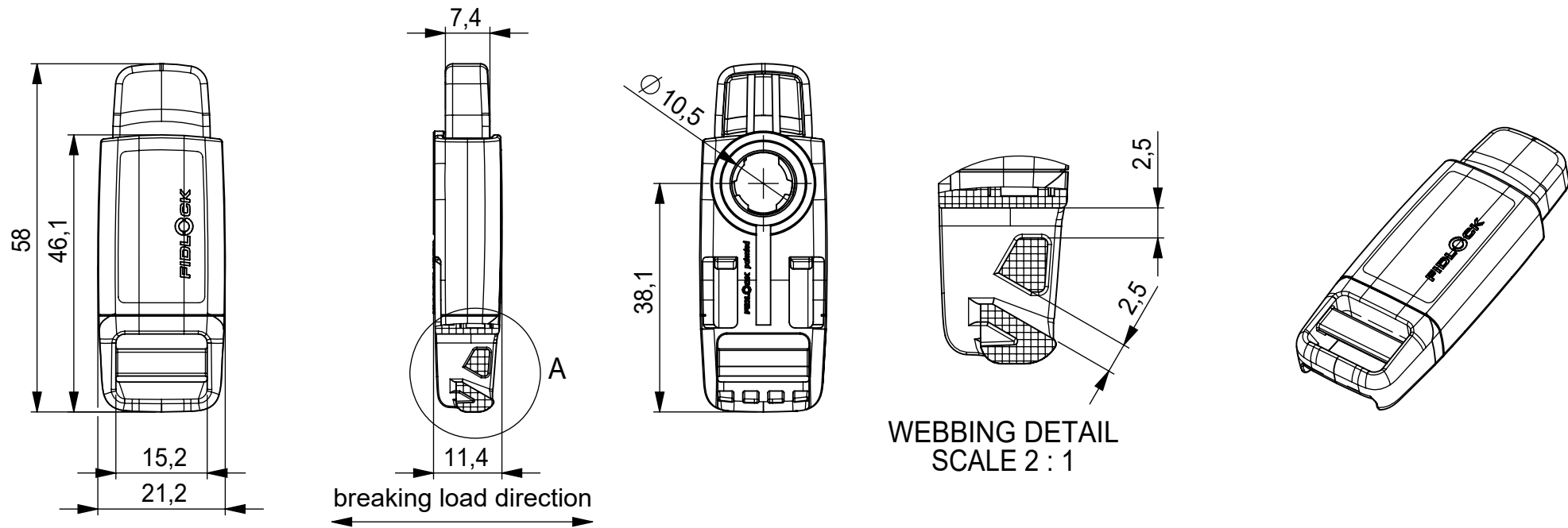

WEBBING DETAIL
SCALE 2 : 1

nominal values in millimeters [mm]

OPENING	push
MATERIAL***	PA66GF (86,6%), NdFeB (11,2%), spring steel (1,9%), other (0,3%)
COLOUR	black
WEIGHT	~ 7,7g (weighed)
BREAKING LOAD**	44 N

GENERAL NOTES*

ARTICLE NO.	F5104-000002(BLK)
PRODUCT	SNAP push female S 15 LL
SCALE	1:1 DIN A4
REVISION / DATE	R00 01.09.25

* The manufacturer of the end products in which FIDLOCK fasteners are used, bears the responsibility for thoroughly testing that the FIDLOCK products are suitable for the intended applications.

** According to test specification QM-TP-001, The static breaking load specification applies in conjunction with the male products 05286 and 05287 and in given breaking load direction.

*** The nominal mass fractions percentage of the materials are given as rounded whole numbers. Fractions below 0.5% are not given.